



Susquehanna Sidetracks

Official Newsletter of the Susquehanna Division
Mid-Eastern Region, National Model Railroad
Association

July 2014

Volume 22 Number 4

From the Superintendent's Desk

Barry Schmitt

Greetings Members,

Welcome to summer and its' heat – long live the heat vs cold!

I sure hope your modeling is progressing better than mine. After living 19 years in our 3-story townhouse my armchair modeling was about ready to advance to building my dream N-Scale version of the B&O Weston WV Branch circa 1965 as an around our 12' x 24' recreation room layout. Sounds ideal – right, but what's that “just about” all about? Just before buying the lumber we decided to downsize to a one floor cottage at the Masonic Village in E-Town. My new designated layout space has shrunk to a 12' square den – plenty of space for an N-Scale layout – right? Oops, I forgot to mention the den will also be my office! Thankfully, being a member of the Masonic Village MRR Club (just about 300 yards from my new front door – hot doggie!) and the Ephrata MRR Club will help drag me out of the “chair” for some hands-on modeling while I await your suggestions on how to fit something reasonable into our new tight quarters. And the answer is a resounding NO

to an almost former model railroad friend's suggestion - downsize to Z-Scale!

Forty members attended an excellent May 10 event at the Masonic Village Welcome Center. Two great clinics were presented – Intro to Dead Rail Modeling by Steve Sherrill that included his modular display layout using the new control system, and the East Broad Top (EBT) Railroad Story by Board of Director member Lee Rainey. Lee's presentation not only discussed the history of the EBT but also served as a great preview of what was planned for our June 28 visit to the property. Also, John Wissinger (MMR) conducted our second Model Showcase program where we had seven member presentations. Be sure to review John's article about the program further in this newsletter. And a very special thanks to the Masonic Village for providing such a great facility - hopefully everyone enjoyed the coffee and donuts that we plan to include at most future clinic-based programs. We also enjoyed visiting three excellent model railroad clubs

See **Super's Desk** on page 2

Schedules

Bowser / Weaver Tour

July 10, 2014

NMRA National Convention

July 13 – July 20, 2014, Cleveland OH

Division Day at PA RR Museum

Sept. 6, Strasburg PA

LSOP6

October 3-4, 2014

MER Convention

October 16-19, 2014, Hagerstown MD

In This Issue

From the Superintendent's Desk.....	1
Second Section	4
Sept 6 th Event.....	4
Database Project	7
Planning the NYO&W p3	9
Modeler's Showcase	13
2014 Division Events	18
EBT Event Review.....	20

Banner photo courtesy of Keith Latimer

Susquehanna Sidetracks

Official Newsletter of the Susquehanna Division
Mid-Eastern Region, NMRA
138 Old School House Ln
Mechanicsburg, PA 17055

Contributing to Susquehanna Sidetracks

Sidetracks welcomes contributions from the Division membership. Letters, articles, photos and other items may be sent to the Editor at the address above or the e-mail address below. Deadline for submission for the next issue is August 18, 2014.

Board of Directors 2014-2015

Superintendent

Barry Schmitt
bschmitt@susquehannanmra.org

Asst. Superintendent

Wayne Betty
wsb@susquehannanmra.org

Chief Clerk

Paul Tice
ptice@susquehannanmra.org

Director/Membership Chairman

Howard Oakes
hoakes@susquehannanmra.org

Director

Dave Collison
dcollison@susquehannanmra.org

Director

Ron Parisi
rparisi@susquehannanmra.org

Director

Lee Rainey
lrainey@susquehannanmra.org

Committee Chairman

Achievement Program Chairman

Robert Charles, MMR
rcharles@susquehannanmra.org

Training & Clinic Chairman

Alan Mende
amende@susquehannanmra.org

Model Showcase Program Chairman

John Wissinger, MMR
jwissinger@susquehannanmra.org

Sidetracks Editor

Ron Smith
rsmith@susquehannanmra.org

Membership Information

Susquehanna Division website:
www.susquehannanmra.org

Mid-Eastern Region website:
www.mer.nmra.org

National Model Railroad Association
8414 Gulf View Drive, Suite A & B
Soddy Daisy, TN 37379-2200
www.nmra.org

that afternoon - the E-Town and Masonic Village Model Railroad Club, the Columbia Model Railroad Club, and the Ephrata Short Line Model Railroad Club. Thanks much for your participation and a special thanks to all who helped make another great model railroading day in the Susquehanna Division.

On June 28 thirty-nine of us enjoyed a great day touring the EBT Railroad and the Rockhill Trolley Museum in Orbisonia PA. Our Division Project Officer and main tour guide for the event was the nationally recognized expert on all things East Broad Top – Lee Rainey. Not only did Lee present a great tour he also persuaded his former employer - Accu-Weather - to provide picture perfect weather. His after event report later in this newsletter is an excellent recap; however, to fully appreciate the outing and absorb the historical significance of the equipment and facilities you simply had to be there. Thanks Lee for a most memorable and enjoyable day!

I hope you have already registered for two exceptional upcoming Division events – our July 10 visit up north to Bowser Manufacturing, English's Hobby Shop, Weaver Trains, and member John Gromley's layout, and our Division Model Railroading Day at the Railroad Museum of Pennsylvania on September 6. By the time most of you read this newsletter our July 10 northern outing will already be history, and hope I had the pleasure of meeting you there.

As for the September 6 event all I can say is Wow! Your Division project team, headed by member Rich Wurst, has lined up a series of exceptional clinics, museum back-shop tours, and model railroad displays to satisfy just about every model railroader's interest. A special thanks to member and Choo Choo Nuts hobby shop owner Rob McClenaghan who is providing the 25 laser kits and construction supplies for the make-and-take clinic – a real touch of class. I want to emphasize the importance of registering and paying before the August 15 deadline – doing so will not only save you money but it will also allow you to participate in one of four back-shop tours and attend the 2+-hour laser kit make-and-take clinic. Those who do not register and pay by August 15 will face a higher entrance fee and not have access to either a back-shop tour or the make-and-take clinic. Also, the special rates, back-shop tours, and make-and-take clinic will only be available to the first 100 (first 25 for the make-and-take clinic) who register by August 15 so be sure to register now. Rich's article in this edition provides added information about the event and how to register. I look forward to seeing you there!

Our November National Model Railroad Month layout open house project is fully underway. The open house dates and associated counties are now set as follows: Southern Sub-Division - Nov 1-2 (Adams, Cumberland, Dauphin, Lancaster, Lebanon, Perry, and York counties), the large Mountain Sub-Division – Nov 8 (Blair, Cambria, Centre, Huntington, Juniata, Mifflin, Snyder, and Union counties out to the west and Columbia,

Lackawanna, Luzerne, Lycoming, Montour, Northumberland, Sullivan, Susquehanna, Wayne, and Wyoming counties up north), and our Eastern Sub-Division - Nov 15 (Berks, Carbon, Lehigh, Monroe, Northampton, Pike, and Schuylkill counties). If you would like to participate in this year's program and have not been contacted by one of our project team members please call me at 717-877-1810 or e-mail: bschmitt@susquehannanmra.org There will be more detailed information about this program in our September Sidetracks.

We are now selecting our 2015 Event Planning Committee members and will have our first meeting in mid-August. Like last year this group will develop our complete 2015 event schedule, assign project officers to each event, and have the program presented to you in our December Sidetracks. Our goal is to allow you to see all that is planned for the year and post them to your calendar before the year begins. If you would like to serve on this committee please contact me ASAP. This is your chance to get involved in Division activities and develop our program for next year. The committee will conduct most of its activities via email and phone but there will likely be one or two in-person meetings. If you have suggestions on events but are unable to serve on the committee please forward your suggestions to me by August 1 so they get into the planning process. And let me take this opportunity to personally applaud the efforts of the team that developed our current 2014 program – members Wayne Betty, David Collison, Charles Kadyk, Forrest Lucas, Howard Oakes, Lee Rainey, Ron Smith, and

John Wissinger (MMR). That team took us from just four events in 2013 to nine this year.

A special thanks to Board of Director member Howard Oakes for his efforts in updating our Division Member Database – see his article on this subject later in this issue. In the past two years several members have complained that they were not getting their bi-monthly Sidetracks and seemed out of the NMRA information mainstream. Each of those problems were traced back to either inaccurate home addresses or faulty or no email address. Once they were updated their information pipeline returned to normal. Were it not for Howard mentioning to me about my needing a change of address following our recent move I would probably be wondering next month “where's my stuff!” So please try to remember whenever you move or change your phone number or email to let Howard know and he will handle all the paperwork for you. Unfortunately, several members he contacted during the past several months have yet to respond. So if you are not receiving your “stuff”, kindly respond to Howard's inquiry and all will be well. We do realize several of you are either in areas where internet service is not available, it's terribly slow, or you do not have or want internet service - oh how I admire those who say no to the Internet! If that is your situation simply let Howard know and we will continue to offer Sidetracks snail mail home delivery. Thanks Howard for staying on top of our large membership program.

Before closing let me offer my personal thanks to the 21 members who sent in ballots for our recent election. Those and our reduced membership cancelation rate demonstrate a vote of confidence from some members that we are at least meeting your expectations. Yes, I know and heard from several members, why vote when there are no choices for each of the three positions up for election? Well, I assure you that was not my doing! I understand that problem because I sat for many years like many of you faced with voting for the same team but never doing anything about it until no one was willing to take this job two years ago. So hopefully over the next two years some of you will step forward and join our Division leadership team. A great way to get started is becoming a member of our many committees and next May placing your name on the ballot for one of four Board of Director positions that will be open for election. But know for sure you will elect a new Susquehanna Division Superintendent in July 2016 so begin identifying and encouraging such a replacement now.

Happy modeling, and I look forward to seeing you at our September 6 Model Railroading Day at the Railroad Museum of Pennsylvania!



Hello Everyone!

Summer is here! After an unusually long winter and lots of rain this spring, I'm sure many of you are ready to get out and about. Lawn mowing often takes precedence over model railroading despite the pile of projects we have going on.

Speaking of projects, I am working on finishing the last 12 square feet or so of initial landscaping on my layout. I have several more buildings to build, but I had put those on the back burner this spring to install decoders in locomotives. Unfortunately, I have not done very well in that department – I broke a frame on one engine and let the smoke out of the decoder on another. Like toothpaste in a tube, once the smoke is out of the decoder you can't put it back in...

Elsewhere in this issue you'll see the results of some of our members' projects. Tom Matthews presents Part 3 of his NYO&W feature, and John Wissinger provides us with a review of the Modelers' Showcase from the May 10th meeting. Howard Oakes has been working on a Membership Database project. Also, see the note from Bob Johnson, South Mountain Division, about the Fall MER Convention in Hagerstown MD on page 19.

We have several events scheduled for the remainder of 2014 and hope you have the opportunity to join us at one or all of them. Also keep in mind that neighboring Divisions have things going on too; if you become aware of an event nearby please feel free to drop me a note about it. My contact information is:

rsmith@susquehannanmra.org

Ron

MODEL RAILROADING DAY at the RAILROAD MUSEUM of PENNSYLVANIA

The NMRA Susquehanna Division is proud to announce a special event co-sponsored with the RR Museum of PA on Saturday, September 6, 2014 from 9:00 AM-5:00 PM. Model Railroading Day is the first collaboration between the NMRA and the RR Museum utilizing museum facilities for special educational clinics and unique tour opportunities.

Presently, scheduled workshops will include:

- Intro to Airbrushing
- Small Space Modeling Concepts
- Tree making
- Make-and-Take laser kit building (limited to the first 25 registrants)
- Building Large Structures with Foamcore
- Train Control Systems (TCS) Decoders
- Structure Scratch Building
- Modeling Layout Scenery.



Model Railroading Day at the Railroad Museum of Pennsylvania

By Rich Wurst



The RR Museum will offer self-guided tours of Rolling Stock Hall, the Dining Car Exhibit, Stewart Junction Railway Education Center and Restoration Shop Tours. Opening remarks will review Museum history, status of the new ‘Roundhouse’ construction project and future projects.

The Restoration Shop is currently working on #460, a PRR E6 4-4-2 locomotive, which set a speed record from Washington, DC to New York City in May, 1927. #460 carried film of the Charles Lindbergh arrival in Paris which was developed in transit. #460 bested an airplane carrying a copy of the same film causing #460 to become known as the “Lindbergh Engine”. Tour participants will have the opportunity to see close-up the state of restoration and have questions answered about techniques and processes used to bring this famous engine back to precise museum specifications.



Model Railroading Day at the Railroad Museum of Pennsylvania

By Rich Wurst

During Model Railroading Day opportunities for inspection of the outdoor rail yard will be available. Participants can view an original Reading RR turntable while observing rolling stock and locomotives housed on several outdoor tracks. Inside Rolling Stock Hall one can view steam and diesel locomotives,

enhance a spectacular day. Especially noteworthy will be a 1-1/2" scale live steam K4 #1361 PRR locomotive on display with the builder, Dave Sclavi (PA Live Steamers) providing information and video clips on his construction and operating experiences.



passenger cars, MOW equipment, cargo rolling stock and numerous special exhibits. The Dining Car Exhibit located in the 2nd floor Gallery is a close up look at railroad dinnerware, menus and the total dining experience offered during the 'golden' days of rail travel.

Several HO, S, and N scale clubs have been invited to demonstrate their modeling and operating achievements for all visitors. This wide ranging scope of model railroading will surely

We are hoping that we have piqued your interest in this special event. The registration deadline is **August 15, 2014**. Registration spots are quickly filling so set this date aside and submit your registration as soon as possible. We have secured special entrance fees for this event from the PA Railroad Museum: NMRA member \$9.00, Non-NMRA individual \$12.00 and Friends of the PA RR Museum \$5.00. For information and registration forms please contact Rich Wurst at 609-658-6156 or rjwurst@comcast.net

Rich Wurst

Membership Database Project

By Howard Oakes

Membership Database Project

The Susquehanna Division 11 receives a member list from the NMRA each month. Division 11 averages about 250 members. Of those 250 members approximately 50, or 20 percent, have no email address.

This means that a significant portion of our members do not receive notification of our activities unless they log on to our website on a regular basis. And they also do not receive emails from the National Association or the Mid-Eastern Region. Most missing email addresses are for members who joined years ago perhaps before the common use of the internet and email.

The Superintendent asked me and Wayne Betty, Assistant Superintendent and Webmaster, to develop a plan to reduce the number of missing email addresses. I sent letters to 53 members that did not have an email address on our records. I received 15 new email addresses and 5 more responded that they have no internet. I also received updates for 5 new phone numbers and 3 new street addresses. While not the 50 percent response I had hoped for, the 20 responses were appreciated. The Region and National are also concerned about their lack of email address but at this time do not have a plan to fix it.

With the July edition of Susquehanna Sidetracks, Wayne will forward to me the email addresses that are returned to him as incorrect, inactive, etc. I will send letters to those members in an attempt to correct those. That number is generally less than a dozen.

If you change your mailing address, phone number or email address please make sure to notify me and I will have it changed on the National, Regional and Division records. If anyone forwards a Railpass application to a director for processing please make sure the phone and email address blocks are filled in. Each month I will continue to contact new members that have any missing information to ensure our correspondence reaches the maximum number of Susquehanna members.

Howard Oakes, Director and Membership Chairman



Upcoming Events In or Near Our Division

Compiled by Ron Smith

**July 10, 2014 (Thursday)
Susquehanna Division Outing
Montoursville, PA**

We'll be visiting Bowser Mfg & Weaver Mfg for a tour of their facility! See page 18 for details

**July 13-20, 2014
NMRA National Convention
Cleveland, OH
www.nmra.org**

**July 19, 2014
3rd Annual PCC Car Day
Rockhill Furnace, PA
Admission \$8 Adult, \$4 Kids
Opens 11 AM, 1st Ride at 11:15
www.rockhillrolley.org**

**August 22-24, 2014
N Scale Weekend
Bedford, PA
10th Anniversary of this All-N-Scale event!
www.n-scaleweekend.com**

**September 6, 2014
Susquehanna Division Day
Railroad Museum of Pennsylvania
Strasburg, PA
See page 4 for details**

**September 20-21, 2014
Mainline Hobby Supply Open House
Blue Ridge Summit PA
Two-day event featuring layout tours within
60 miles of Mainline Hobby Supply.
www.mainlinehobby.net**

**September 27-28, 2014
Tidewater Division
Virginia Beach, VA
25th Annual Show and Sale
Virginia Beach Convention Center
<http://nmra-mer-tidewater.org>**

**October 3-4, 2014
L-SOP6
Lehigh-Susquehanna Operations Weekend
(All slots are full)**

**October 16-19, 2014
MER Fall Convention
Hagerstown, MD
www.mer.nmra.org**

Free Railpass Trial Membership Sponsored by the MER

Do you know a modeler who needs a nudge to take the next step to become more involved in this wonderful hobby? The trial membership program may be just what is needed to further a modeler's development, skills and interest.

The NMRA began a 6 month 'Railpass' trial membership program which costs the applicant \$9.95. The Mid-Eastern Region (MER) has built on this program by paying the \$9.95 Railpass fee for applicants

residing in the MER. In other words, the MER is furnishing a free 6 month NMRA membership to encourage the recruitment of new members.

Railpass applicants will receive 6 issues of the NMRA Magazine, 3 issues of the Local, eligibility to attend conventions and meets and to participate in contests. Railpass applicants cannot vote or hold office, and will not receive the New Member Pak from national. Anyone living within the MER who has not been an NMRA member during the past 2 years can use this program.

The prospective member fills out the free MER Railpass membership application form on page 24 of this issue (not the standard NMRA Railpass form), and give it to a Division Director who will sign and forward it to the MER for processing. Do not send this to Bob Price or the NMRA headquarters in Chattanooga, TN; the MER will forward the application to the NMRA with the payment.

Planning for the NYO&W, Part 3

By Tom Matthews

Wiring and the Scenery Base

As a refresher from the March issue, my objective is to build a model of the New York Ontario & Western in the final ten years over an eleven mile stretch from Cornwall to Campbell Hall. In the second installment, I left off at the “GATE” for the NY Central West Shore to cross the aisle at Moodna Creek. The next section from there would be the Newburgh area, but I’m going to take you on a trip up the NYO&W from Cornwall this time.

This layout has seen a slow start. I started construction in 2004 when we bought the basement (house). While being away from home four days a week until retirement in 2013, the layout - and the house - didn’t get the attention they wanted. You can ask my wife Jane; she didn’t get much attention either. So, this section from Cornwall through Firthcliff had plenty of time to stew. By stew, I mean I was learning about lots of new ways to do things as I progressed. In the years since my last layout I had done a lot of armchair modeling and many of the articles I had read about new methods never sank in. So, off I go building a large layout the same way I had always done it.

In 2006 I had built a panel to control turnouts at Firthcliff. Then, at an Op Session I discovered how much easier it would be to use DCC to help me with all that. Over the years I had read all of Dr. Bruce Chubb’s work on CMRI (Computer Model RR Interface) and now I could use that information along with available components to control my empire.

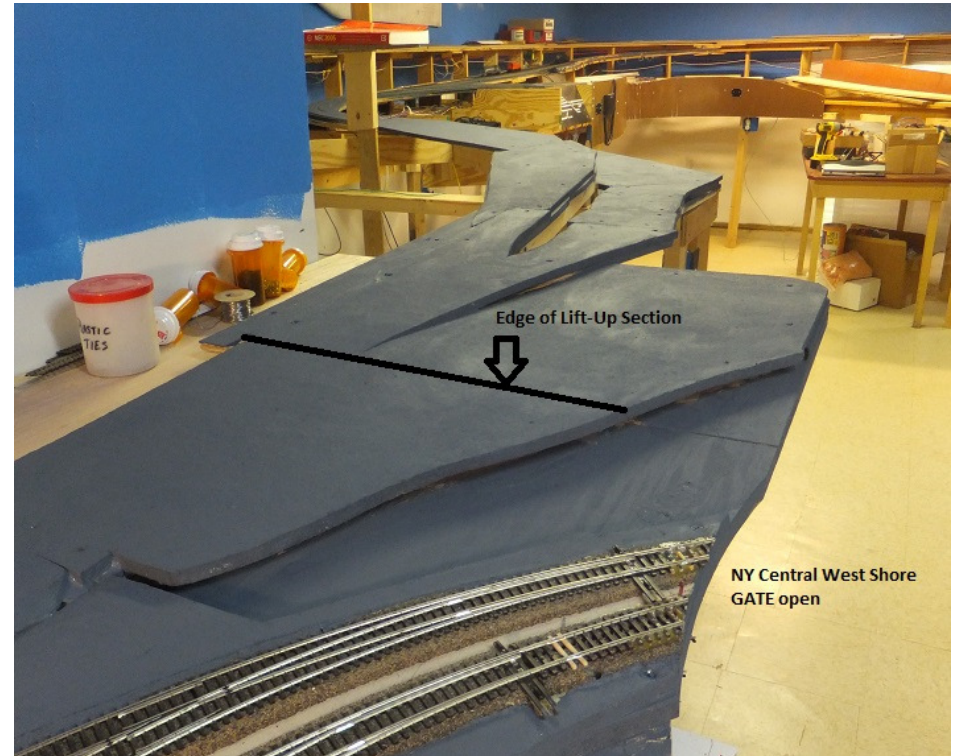

Figure 1

Along the way I learned about using whatever is available, DON'T. Here is one reason why:

I had four 500ft spools of bell wire (22g solid copper). I figured it would be great for track feeders from the DCC Bus. Unlike many who follow NMRA RPs and use Red & White, I chose Black & White since I had that on hand in large quantity. I also had on hand over 800ft or 12g Black & White stranded for busses.

Planning for the NYO&W, Part 3

By Tom Matthews

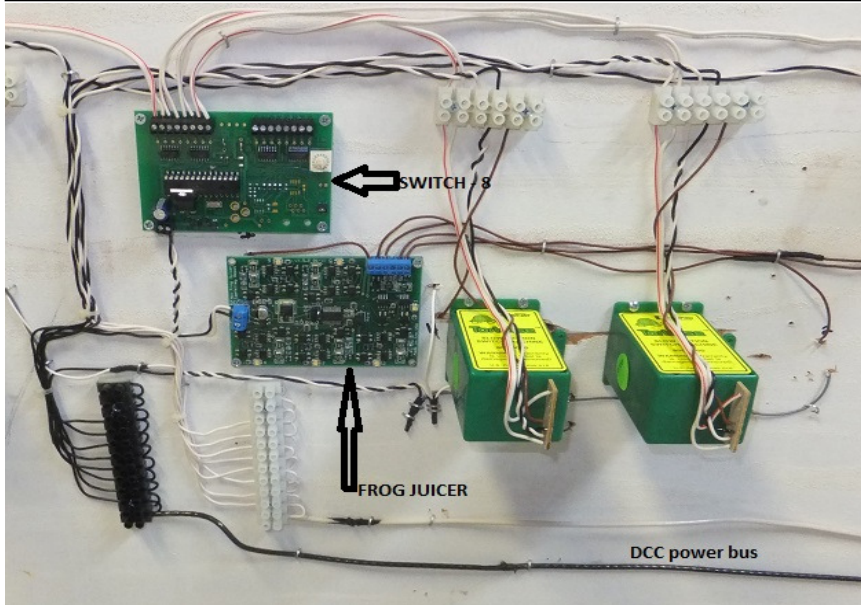

Figure 2

Maybe the 22g bell wire was old but it didn't seem brittle. Some insulation broke where I twisted it a bit tightly and caused a nightmare of short circuits. I'll continue to use the wire but carefully.

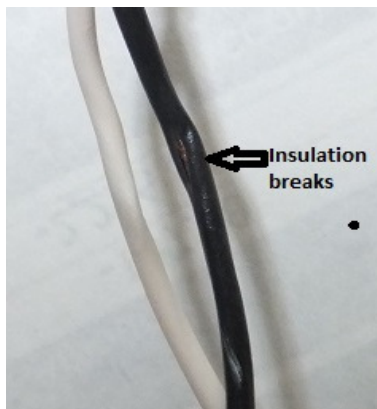

Figure 3

Using the digital approach to controlling turnouts will not only cut down on some of the wiring, but more importantly, it would allow a dispatcher (call it the owners' central control point for now) to have or give control of any turnout as needed.

At first I only had control of the turnouts through the hand held throttles via the Accessory feature. This could cause quite a few problems (derailments) when a person throws the wrong turnout. To solve this, toggles were installed in the fascia directly in front of each turnout. They are "belly proofed" by having them recessed:



Figure 4

The toggle is threaded into a 1/4" hole in the end of a PVC pipe cap. The cap, after wiring, is fitted into a hole in the fascia and two dabs of latex caulk hold it well but it can be removed if needed.

Planning for the NYO&W, Part 3

By Tom Matthews

Now the computer fun begins. Using JMRI Panel-Pro (free software download at JMRI.ORG), the turnouts are programmed to be thrown by the momentary contact toggles wired to an NCE Mini-Panel.

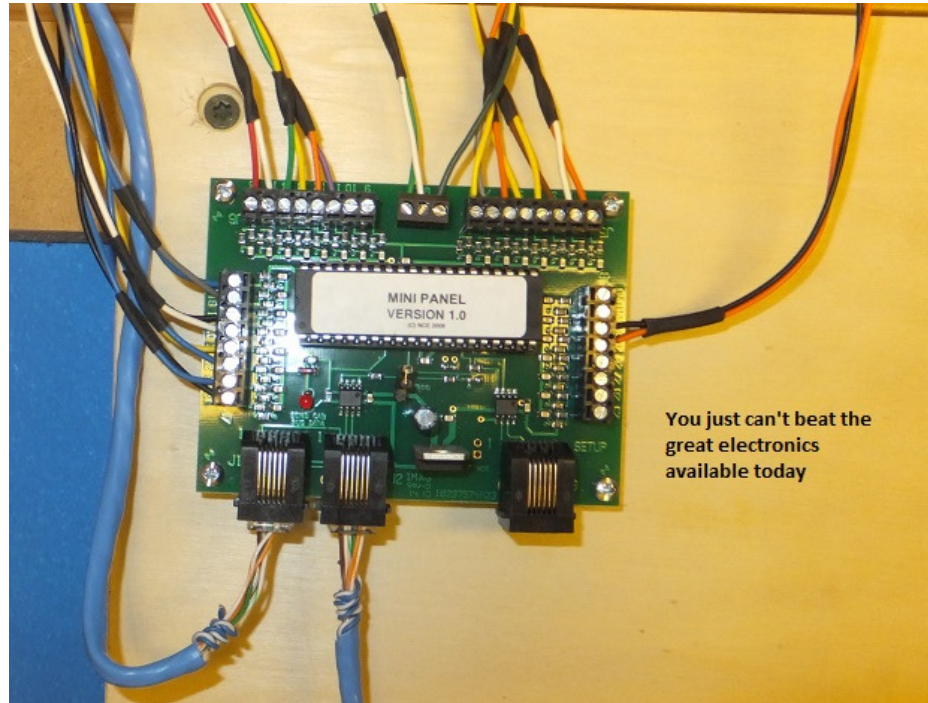

Figure 5

A Dispatcher control panel can be built with actual toggles or a virtual panel can be built in Panel-Pro (see Bob Bucklew's tutorial):

http://www.quaker-valley.com/CTC/JMRI_Panel_Tutorial.html

I am building the virtual panel from which the dispatcher (spelled OWNER) will have the control needed to ALLOW operators to throw only needed turnouts.

Another thing that has changed a lot since the last layout I built (over 30 years ago) is scenery. So much COOL STUFF is available today. Starting with the scenery base - who would have thought of using anything but window screen with plaster augmented with good old asbestos?

Well, you can teach an old dog a new trick. I started using insulation foam for the base. At first I tried cutting it with a hot-wire knife. Yes, you can cut intricate details with a hot-wire, but we're only dealing with the base here. It doesn't need detail yet, so I resorted to slicing it up with a "box cutter" type knife, the type with the retractable blade that can be snapped for a fresh edge. The advantage to that type of knife is that you can extend the blade several inches to slice through 2" foam very easily. Carpenters glue will bond the foam, BUT it will take forever to dry as the foam does not "breathe". I found that spray foam insulation "Great Stuff" is indeed great stuff. A small bead placed on the surface, and then the pieces placed together and worked (wiggled) a bit will spread the foam like glue. It does not attack the foam as solvent adhesives will. It can be used to fill void areas but avoid using it more than 2-3 inches thick as the center will remain wet for a long time and when you go to cut it the knife will be a mess.

Planning for the NYO&W, Part 3

By Tom Matthews

I find that using plywood at any roadway or large structure location helps to establish a good level base. Small structures can be cut into place later, but those large ones at trackside should be well established.

Work is progressing along the NYO&W and next time we will look at the high trestle between Firthcliff and Fiction Junction. Here is a peek with the temporary trestle in place to run trains.

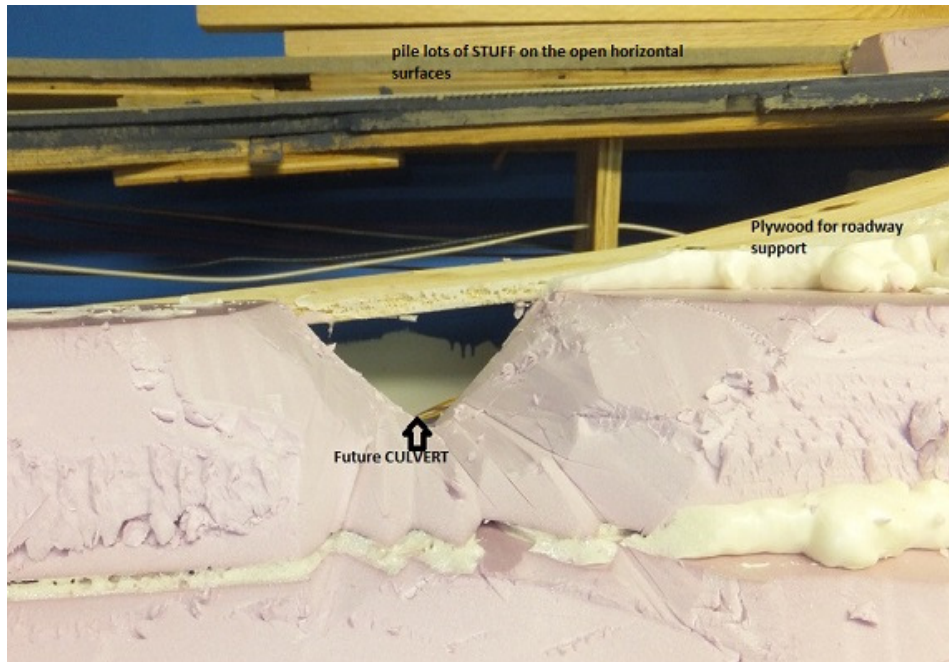

Figure 6

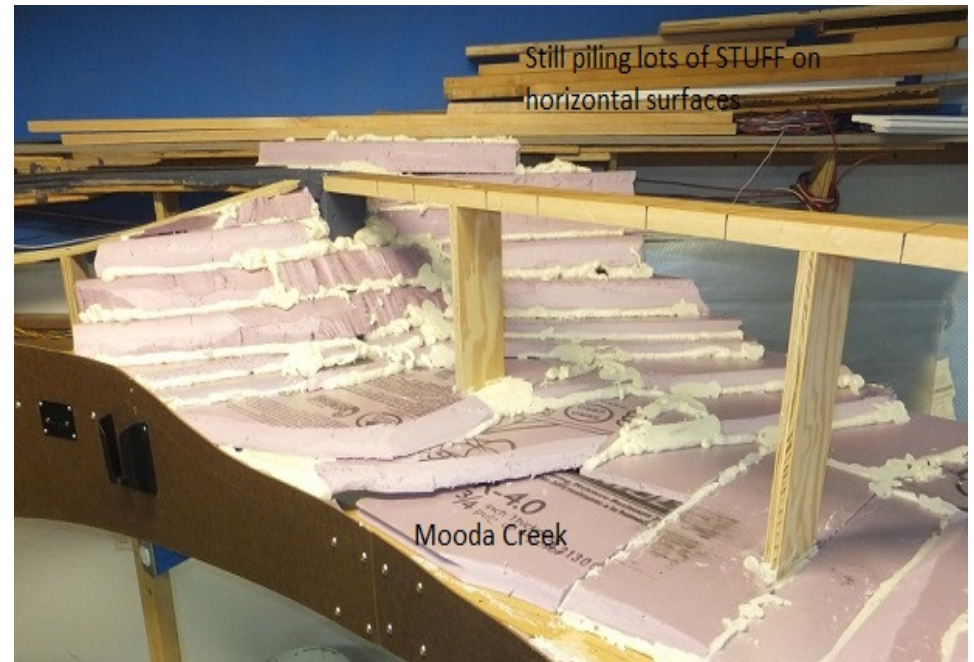

Figure 7

Did I say FICTION JUNCTION? That's another story for another day.

Tom Matthews

Photos from the May 10th Division Meet: Modeler's Showcase

Article by John Wissinger, MMR

Model Showcase May 10, 2014

By John Wissinger

The second edition of the Model Showcase was held at the May 10 Division 11 NMRA meeting at the Masonic Village in Elizabethtown. Six modelers displayed their railroad models. The following is a description of each model. Some of the descriptions and photos were supplied by the modelers after the meeting for this article.

Lee Rainey brought one of his Sn2 modules that depict a haying scene in the early 1900s. His modeling goal was to suggest a major "industry" along the 2 foot Maine narrow-gauge Wiscasset, Waterville & Farmington RR, which earned its living by serving local farmers. Lee explained how he kit-bashed both the oxen and the haying crew from figures originally doing other tasks. The ground cover was made from an Efsi grass mat and the hay rows are Woodland Scenics weeds. The module forms part of the large FreeMo layout of The Sn2 Crew. You can see their whole setup at the NMRA's National Train Show in Cleveland this summer.

(Two photos at right courtesy of the Bricktown Model Railroad Club.)



Photos from the May 10th Division Meet: Modeler's Showcase

Article by John Wissinger, MMR

Dennis Blank Jr displayed several models of locomotives and rolling stock. They included an RS-1 locomotive (Atlas), boxcar and tank car (Tichy) and more Tichy cars from the work train, a Doodlebug (Walthers), 2 GP30's (Proto 2000), Crane and boom car (Tichy). Three covered hoppers are Kato models that are a work in progress for a patch job. He also had 2 low side gondolas with the real wood floors from Funaro & Camerlengo, a Bowser caboose and MDC/Roundhouse caboose.



(Dennis Blank Jr photo)

John Wissinger had an American Laser Models Interlocking Tower Kit which he super detailed the interior with an "armstrong" lever machine, operator's desk, chairs and potbelly stove along with an operator working the levers. A typewriter, telephone, telegraph key and other details are on the desk. Rafter tails were added to the underside of the roof. Several of the windows were partially opened and some have partially drawn shades. Exterior signs were added to give the location of the junction and operating lights were added above the doors on the first and second floors as was an interior light. These details were based on articles in a 1962 MR showing details of interlocking towers.



(John Wisinger photo)

Photos from the May 10th Division Meet: Modeler's Showcase

Article by John Wissinger, MMR

John Frantz displayed cabooses and locomotives. *(All photos on this page are by John.)* Below, CR N8A Caboose 23669, an Overland Models brass import painted with Floquil and lettered using a decal set by Mount Vernon Shops.



Below, CR N5B 22885 Caboose, a Bowser kitbash, was originally written up for the February 2013 Model Railroad Hobbyist.



Locomotive CR ALCo T6 9845 was purchased from the estate of a deceased friend, George Slonaker, as an "in-progress" kitbash. At that time it was a brass shell on a gutless Hobbytown switcher chassis. Originally an ALCO Models Brass Import of an ALCo T6

in the N&W configuration with MU-capable end railing, the railings were removed to make this into a PRR model, which purchased all 6 of theirs from ALCo without MU capabilities. To make it more DCC friendly, a Proto 2000 switcher chassis was heavily milled and modified to accept the brass body shell. Then the model was detailed as appropriate and painted using Floquil, weathered using AIM Powders, and decaled using a mix of Microscale, Walthers and Mount Vernon Shops decals. Finally a Loksound decoder was installed with the correct prime mover sounds.



CR GP35 2289, below, a Kato unit that was detailed, painted, and lettered to match a photo of the same unit as it appeared in 1978 in Conrail's Ex-PRR/PC Enola Yard.



Photos from the May 10th Division Meet: Modeler's Showcase

Article by John Wissinger, MMR

Alan Mende had a model diorama of an N&W Station Master's house in Island Ford, VA (two photos at right). Alan scratch built the house and out buildings and other details. He wrote 2 articles in the October and November RMC detailing the history and construction of the model which he related in the Model Showcase portion of the meeting. This was a well detailed model that had to be viewed up close to be appreciated.



(Two photos by Barry Schmitt)

Fred Phillips brought his finished model of the Dando's Breaker project that was featured in the March 2014 *Sidetracks* (Vol 22 #3). The prototype of the breaker (anthracite coal tippie) was built during WW II in Llewellyn PA in Schuylkill County. Since the prototype was wood, it made an interesting prototype to model. He will be entering it in the model contest at the NMRA National convention in Cleveland. It is a nice model and I wish him well. (See Fred's photo on the next page)

Photos from the May 10th Division Meet: Modeler's Showcase

Article by John Wissinger, MMR

The Model Showcase has been a success for the first two outings. It has allowed some of our talented modelers to showcase their modeling efforts and there were some very nice models shown.

However, this is not what I had in mind for the program. I wanted to see more models and participation. I have been an NMRA member for about 44 years and have been a member of about 8 divisions across the country and have seen several versions of models on display: "Show and Tell," "Bring and Brag," "Model Contest," etc. A table was set aside for model displays; model contests where the popular vote won the contest; modelers sitting around the room held up their model and gave a brief description, if you did not bring in a model, you contributed to the kitty.

Some Divisions had more models on display than others. The last (above) was, in my opinion, the most successful as far as participation was concerned. Although there was usually a theme set the month before (hopper cars, open top cars, refrigerator cars, house cars, RR support industries, line side structures, commercial structures, etc. favorite model or current project), if you did not bring in a model you contributed \$0.50 to the kitty. In that division, 80-90% of the people brought in models, the others helped to keep the division solvent. This gave everyone a chance to participate.

What is your opinion? Please let me know at a future division meeting or email me (put Model Showcase in the subject line) at: wissinger@susquennanmra.org.

John Wissinger



2014 Division Events

Brief Descriptions of Upcoming Division Events

July 10, 2014 - Bowser, English, and Weaver Visit

We have scheduled tours to Bowser Manufacturing and Weaver Scale Models on **Thursday, July 10**, so be sure to add this to your future model railroading activities. The weekday visit is necessary because tours are not available on weekends when the businesses are closed.

Bowser is located in Montoursville PA, and has been a well-recognized model railroading name for decades. Their factory store and hobby shop, English's Model Railroad Supply, is just a few blocks away from the primary Bowser facility and will also be visited during our tour. Finally, Weaver, another highly respected model railroading name, will be included on our tour, and they are located in Northumberland, PA where they produce the well-known line of Scalecoat model paints.

Business addresses, directions, carpooling/group caravan opportunities from various Division locations, and maps were included in a more detailed Sidetracks article that appeared in our May newsletter. (At that time you were requested to register for this event so we could provide our hosts with an accurate number of attendees.)

These same tours were done way back in 2006 and were definitely a hit. Since then we have received many requests for return visits. This is your chance to see how models are made with injection molding machines, pad printing of road names, assembly, and testing. It is also part of our goal to offer Division activities throughout our large territory; accordingly, we look forward to meeting many of our northern members at this event.

Project Officer: Howard Oakes

September 6, 2014 - Susquehanna Division Day at the Railroad Museum of Pennsylvania

See page 4!

September 20-21, 2014 Mainline Hobby Supply Open House

Mainline Hobby Supply of Blue Ridge Summit, PA will once again be holding their annual Open House on the third weekend of September. Along with food and a sale on their already-great prices, the store arranges for area layouts to be open for visitors during the weekend.

The store will have expanded operating hours that weekend – they will be open Saturday from 9-5 and Sunday from 12-5. Our Division will also have a table set up both days so your non-member friends can learn about all the advantages of joining the NMRA and then sign up for our free six-month Rail Pass membership program that includes just about all full membership benefits during that trial period.

There will be layouts located within our Division that will be open during the weekend. There will also be several more outside our division area that are certainly worthy of a visit. We'll provide a comprehensive list of local layouts in our September *Sidetracks*.

Mark your calendars now for this long-standing South-Central PA tradition!

Project Officer: Ron Smith

2014 Division Events

Brief Descriptions of Upcoming Division Events

October 4-5, 2014 - LSOP-6

This is another annual tradition in the Fall for South-Central PA. As of this writing all slots are full, but if anything changes we'll provide an update in the September issue.

Project Officer: Wayne Betty

October 16-19, 2014 - MER Hagerstown MD Convention Layout Open Houses Program

As most of you probably know by now the South Mountain Division is hosting the 2014 Mid- Eastern Region NMRA Convention in October of this year. The convention will be held in Hagerstown MD on October 16th through the 19th (Thursday through Sunday). One of the highlights of any convention is the layout tours. This year's convention will feature early bird tours on Thursday night (Hagerstown area only)) and afternoon tours on Friday, Saturday, and Sunday.

Eighteen individuals have already volunteered to host layout tours and I want to take this opportunity to thank them for their support for the convention program. That being said, there is plenty of room for additional layouts to be open during the convention. If you have not volunteered yet, and would like to host a layout open house during the convention or have questions about the project, please contact me (Bob Johnson – rcyrilj@aol.com or 301-606-5797) as soon as possible and indicate the days you could be open.

Please understand that tours are scheduled to create area routes which allow convention participants to visit multiple layouts in the same general area on any given day. This helps to ensure that the layouts that are open have enough visitors to justify the effort the host invests in preparing for their open house. This means that if a single individual volunteers to host a layout tour, and there are no other layouts in their area, we may choose to leave them off of the schedule, unless they indicate that they understand that they may not have many visitors but want to be open regardless.

We hope to see all of you at the convention!

Bob Johnson – MER South Mountain Division

November is Model Railroad Month!

Don't forget about upcoming layout tours during each weekend of November as we celebrate National Model Railroad Month. Stay tuned for details!

East Broad Top Railroad – June 28 Event Review

Article by Lee Rainey, Photos by John Wissinger

Susquehanna Division Visits the Rockhill Trolley Museum and East Broad Top Railroad

Thirty-eight railfans converged on Rockhill Furnace, PA on June 28, 2014, for the NMRA Susquehanna Division Day at the Rockhill Trolley Museum and the East Broad Top Railroad.

The day began with a visit to the Rockhill Trolley Museum - www.rockhilltrolley.org - which operates historic standard gauge trolleys over a portion of the EBT's former Shade Gap Branch through the beautiful Blacklog Narrows. Motormen Joel Salomon and Charlie Wootton complemented the ride with a series of talks about the museum and its operations. Then Joel led a tour of the museum's large collection of historic equipment – ranging from tiny single-truck street cars to handsome interurbans and modern rapid transit vehicles, including the only surviving, operable Electroliner.



The attendees gathered in front of the EBT's 1874 roundhouse for a group photo



The tour offered an opportunity to inspect equipment ranging from a snow-sweeping trolley (near left) to a PCC car (left distance) and a single-truck streetcar (right).

East Broad Top Railroad – June 28 Event Review

Article by Lee Rainey, Photos by John Wissinger

After lunch, attention turned to the East Broad Top. Dennis Straub and Bob Harris of the Friends of the East Broad Top - www.febt.org - manned informational displays, and veteran tour guides Lawrence Biemiller and Lee Rainey gave comprehensive tours of the narrow gauge railroad's machine shops, roundhouse, and yard. The fully equipped machine shop, foundry and blacksmith shop demonstrated why the EBT has been described by the Smithsonian as "the best preserved example of a 1900 industrial site anywhere in the country." The visitors also had the opportunity to inspect the six steam locomotives and the EBT's unique gas-electric car, slumbering in the roundhouse while awaiting the resumption of tourist service. The visitors also had an opportunity to inspect the restoration work being done on cars and buildings by the Friends of the East Broad Top.



The EBT roundhouse not only is home to six narrow gauge Baldwin Mikados, such as #14 (right), but also the only narrow-gauge Brill-Westinghouse gas-electric, the EBT's M-1 (left)



Filled with machinery dating from the turn of the last century, a portion of the EBT shops has been reactivated by the FEBT crew to support their restoration efforts.

Judging from e-mail chatter after the event, everyone who attended felt the day was a great success. If you missed it, you have a second chance. A similar day of trolley ride and tours is planned as a field trip on October 18 from this fall's Mid-Eastern Region convention - www.smdnmra.org/hubcity.html - which is headquartered in Hagerstown, MD.

Lee Rainey

Train Derailment in Montana

Compiled from various media outlets by Ron Smith

And this just in...

By now you have heard of the Montana Rail Link derailment in Montana that occurred on July 3rd. The train was carrying six Boeing 737 fuselages from Wichita KS to Renton WA. All six fuselages were involved, with three of them ending up in the Clark Fork River.

Although this is a serious incident indeed, no one was injured. Some initial reports identified the event as a BNSF accident, but later reports corrected it to identify it was a Montana Rail Link accident. However, I feel compelled to share the headline that the Weather Channel chose to use on its website:

“Three Planes Plummet into Montana River.”

Certainly an attention-getter, eh? But think of the modeling possibilities here. You can have airliner fuselages on your layout without the need for large-radius curves! No space-hogging airport scene either – you only need a layout-edge scene of a cliff ending in a river bank...

Our Division Super, a retired airline pilot, notes that he has already heard rumors that Southwest put in a bid for these...



Train Derailment in Montana

Compiled from various media outlets by Ron Smith



Free Railpass Trial Membership Sponsored by the MER

**National Model Railroad Association (NMRA)
Mid-Eastern Region
Application for Free "Railpass" Trial Membership**

Yes, please sign me up for a free six-month Railpass trial membership in the NMRA – which includes membership in the Mid-Eastern Region and in my local Division. During this six month period, I understand that I may attend conventions and meets, and participate in contests. I will receive **NMRA Magazine**, the national monthly magazine, and **The Local**, the bi-monthly regional newsletter. I will not be eligible to vote, hold office, or receive a New Member Pack.

I also understand that the \$9.95 cost of this six month Railpass trial membership is being paid by the Mid-Eastern Region. (Regardless of who pays, six month \$9.95 memberships are available once to each person.) At the end of the six months, I may join the NMRA, paying the regular active member dues.

During the past two years, I have **not** been a member of the NMRA.

Name: _____

Street Address: _____

When this form is completed, mail it to:

City / State / Zip: _____

Phone: (_____) _____

E-mail: _____

Scales(s): _____ Date Of Birth: _____

Signature of Applicant: _____

Signature of Sponsor: _____ (Required)

Do not mail it directly to NMRA headquarters in Chattanooga TN

(A Divisional or Regional officer or board member)

Date of Form: 2/1/2013

**Bob Price
MER Business Manager
666 Princeton Avenue
Collingswood, NJ 08108**

Business Sponsor

Choo Choo Nuts

Celebrating Our One-Year Anniversary!!

- New & Used Trains Sold Here
- Consign OR Trade
- Modeling Supplies, Paints & Tools
- DCC Installation
- Repair & Restoration
- We Buy Trains!
- Collections / Estates



717-208-3398

TUE-FRI 10-6 pm SAT 10-4 PM

444 E. Roseville RD, Lancaster PA 17601
(1821 Oregon Pike Behind McDonalds)

Business Sponsor

MAINLINE HOBBY SUPPLY

15066 Buchanan Trail East
Blue Ridge Summit PA 17214
(717) 794-2860
Monday-Thursday 10-6
Friday 10-9
Saturday 10-5
Sunday 1-5

www.mainlinehobby.net

Serving the hobby for 25 years!!

***You're one-stop source for all your model
railroading needs.***

From Z to O, from DCC to Detail Parts, we have it all!

e-mail: sales@mainlinehobby.net



Business Sponsor

The Station

213 Ninth Street
New Cumberland, PA
Phone: 717-774-7096

Please call for directions

Open Tuesday-Friday 10 AM to 5 PM
Saturday 10 AM to 2 PM

Extended Fall & Winter Hours (Saturday/Sunday/Monday)

TRAINS EXCLUSIVELY

ALL GAUGES (G-O-027-HO-N-Z)
Sales & Service



Susquehanna Division #11 Newsletter MAIL Subscription Form

Mid-Eastern Region, National Model Railroad Association, Inc.

Send form to: Paul Tice, 6710 Moul Road, Thomasville, PA 17364

_____ \$11.00 per Year _____ Change of Address
_____ Number of Years _____ Total Amount Enclosed

The Susquehanna Division is located in the central portion of Pennsylvania. The Counties served are: Adams, Berks, Blair, Cambria, Carbon, Centre, Columbia, Cumberland, Dauphin, Huntingdon, Juniata, Lackawanna, Lancaster, Lebanon, Lehigh, Luzerne, Lycoming, Mifflin, Monroe, Montour, Northampton, Northumberland, Perry, Pike, Schuylkill, Snyder, Sullivan, Susquehanna, Union, Wayne, Wyoming, and York.

If you wish to have the newsletter mailed to you, rather than having it sent via e-mail, you must subscribe.

Make checks payable to "Susquehanna Division 11"

Name _____
Address _____
City _____ State & Zip Code _____
Telephone _____ NMRA # _____

Susquehanna Sidetracks

Official publication of the Susquehanna Division 11
Of the National Model Railroad Association

138 Old School House Ln
Mechanicsburg, PA 17055